

DAEDONG ENGINEERING CO., LTD.



AUGER VIBRO HAMMER

DPD350TA (NEW)

- Innovative multi-function piling system
- Auger drill and Pile driver are attached into the one unit
- Up to double greater productivity than auger drill and crane of pile driver
- Unique technology designed by AVH technology, which is the first in KOREA Patented
- High quality products which is designed by ISO9001 system
- Increases productivity by cutting time spent on each job

TECHNICAL FEATURES

Pile Driving & Extracting Working

- 1) Maximum 11mt driving, extracting, arranging sheet pile, H-beam, Tube
- 2) Pilot Double-check system holds clamp presser until released, thus increasing workers safety
- 3) Operator can easily control sheet pile, H-beam and tube by himself due to its 90 degree tilting
- 4) The 360 degree rotation and the double-axis of movement allow for full range of motion
- 5) Substantially reduces costs by eliminating equipment manpower typically used in piling operations

Auger Drilling Working

- 1) For auger operation, the screw can be easily attached & detached operating vibratory hammer normally
- 2) Drilling of soil, weathered & soft rock with power pack during auger rotation and vibration operation
- 3) Can be applied for ground release drilling, ground investigation, before sheet piles
 - Multi-functional equipment enabling sheet piling and auger drilling
 - Powerful vibration and clamping power is the best in this class equipment
 - Upgraded durability by hydraulic bearing and powerful motor for high speed rotation
 - Specially designed heavy duty elastomers of Patent which is excellent performance in high frequency vibration of 3,000 cycles per minute
 - Unique technology designed by AVH technology, which is the first in KOREA Patented and CE certified
 - Strong & powerful DPD350TA can perform the same operation as DH hammer
 - Introducing innovations to the field of vibration drilling techniques with our R&D team who can adapt to the developing technology and who refreshes itself progressively in order to satisfy all the needs.

	Model	Units	DPD350TA
Vibration Part	Static Moment	in.lbs	400
		kgm	4.6
	Frequency	VPM	3000
	Centrifugal Force	lbs	67410
		kN	300
	Amplitude	inch	0.27
		mm	6.8
	Hydraulic Operating Pressure	bar	200
		psi	2900
	Hydraulic Setting Pressure	bar	240
		psi	3480
	Oil Quantity	l/min	160~240
gpm		42~64	
Hydraulic Motor Power	kw	60	
	hp	79	
Auger Part	Output Torque	Kg-m	2000
		ft-lbs	14466
	Rotating Speed	rpm	10~20
	Oil Flow Required	l/min	54~110
		gpm	14~29
	Power Pack (Accessory)	KW	52
		hp	70
		l/min	110
		gpm	29
		bar	240
psi		3480	
Dimension	Height (A)	inch	85.8
		mm	2180
	Length (B)	inch	52
		mm	1320
	Width (C)	inch	30
		mm	762
	Upper Pin (D)	Inch	13.5
		mm	345
	Clamping Jaw (E)	inch	1.6
		mm	40
Turning		degree	360
Tilting		degree	90
Weight	Main Body	lbs	4806
		kg	2180
	Extension Boom	lbs	1298
		kg	590
Applicable Excavator		Ton	28~40

Materials and specifications are subject to change without prior notice

 **DAEDONG ENGINEERING CO., LTD.** Innovative, Reliable and Original Vibration Technology

Vibro Rippers : Vibro Breakers : Pile Driver : Auger Vibro Hammer : Telescopic Hammer : Auger Drill : Vibro Rock Drill : Concrete Vibrator.

DRAWINGS

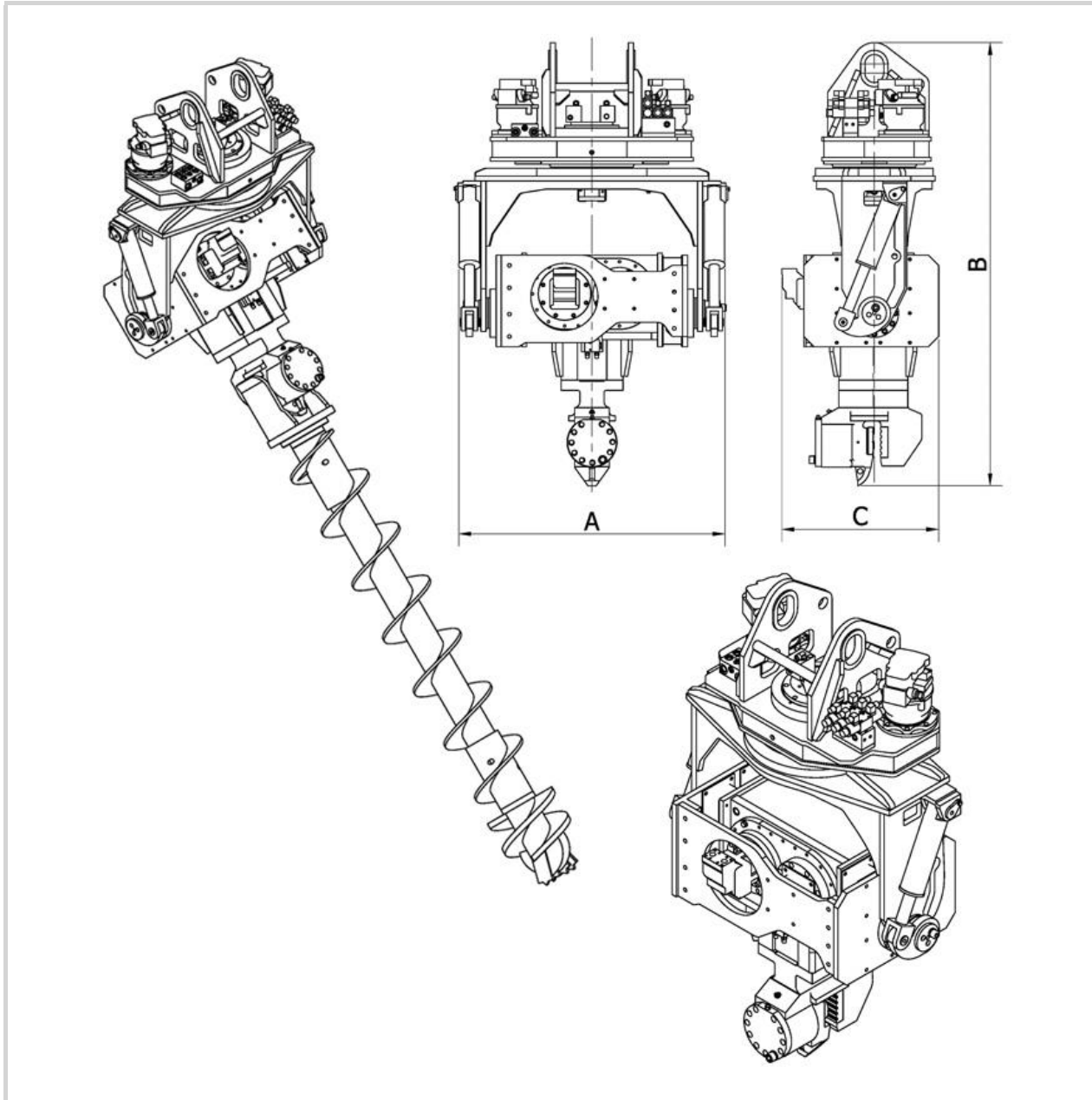

FOR QUESTIONS OR ENQUIRIES PLEASE:

EMAIL: enquiries@epindustries.co.uk OR CALL: +44 (0) 1773 606501